

## Content

<b>1. General information .....</b>	<b>2</b>
1.1. Long tradition .....	2
1.2. Quality of products.....	2
1.3. Notice .....	2
<b>2. General technical information .....</b>	<b>2</b>
2.1. Cleanliness of working fluid .....	2
2.2. Working fluids.....	2
2.3. Temperature and viscosity of working fluid .....	2
2.4. Working environment.....	3
2.4.1 Ambient temperature.....	3
2.4.2. Cleanliness of working environment.....	3
2.4.3. Potentially explosive atmospheres.....	3
2.4.4. Corrosion protection .....	3
<b>3. Overview of products.....</b>	<b>4</b>
3.1. Valves - divided into groups .....	4
3.1.1. Directional control valves.....	5
3.1.2. Check valves .....	8
3.1.3. Pressure valves .....	9
3.1.4. Overcentre valves .....	11
3.1.5. Flow control valves.....	11
3.1.6. Proportional valves .....	13
3.1.7. Explosion-proof valves.....	16
3.2. Actuating solenoids.....	16
3.3. Manifolds.....	18
3.4. Hydraulic power packs .....	19
<b>4. Packaging of products .....</b>	<b>21</b>
<b>5. Spare parts and accessories .....</b>	<b>21</b>
<b>6. Installation.....</b>	<b>22</b>
<b>7. Classification of ARGO-HYTOS products into groups according to level of danger .....</b>	<b>23</b>
<b>8. General safety principles for installation, handling and operation of hydraulic equipment .....</b>	<b>24</b>
<b>9. Reliability of products according to EN ISO 13849 .....</b>	<b>25</b>
<b>10. Applied materials.....</b>	<b>26</b>
<b>11. Validity of catalogs .....</b>	<b>26</b>

## 1. General information

### 1.1. Long tradition

Hydraulic components have been manufactured in Vrchlábí since 1956 and this tradition continues to today. We have gained insight and experience, developed innovative ideas, and optimized design parameters using mathematical models, computer analytics and simulation and physical prototypes for many years. All of this is a prerequisite for the development and production of new modern products intended for both stationary and mobile applications. Our product portfolio includes the valves designed for the control of hydraulic circuits, manifolds, and power packs used as hydraulic drives. We manufacture both standard products which can be found by the customer in our catalog and custom-made products for specific applications. We participate in the development and implementation of technical projects together with our customers. Complex projects represent a welcome challenge for us.



### 1.2. Quality of products

Customer satisfaction is our number one priority. Only properly functioning equipment brings our customers and us satisfaction. The certified quality assurance system is fully implemented in our manufacturing and assembly processes. High-quality engineering materials purchased with the certification of reputable suppliers are used to manufacture the parts. High precision machining is performed on CNC machine tools. Key valve parts undergo heat treatment to be able to withstand wear and meet the high demands on service life. Functionality of all products is verified on computer-controlled test benches. Therefore, the decision on the product conformity is independent of human error. Climate resilience of surface treatment against corrosion is verified by an accredited laboratory. The chosen products were certified by the internationally recognized certification authorities such as TÜV or CSA.

Service life of hydraulic valves (unless otherwise specified in the catalog)	
Solenoid operated valves	1 × 10 <sup>7</sup> cycles
Manually / mechanically operated valves	1 × 10 <sup>6</sup> cycles

### 1.3. Notice

Please pay attention to the following general rules concerning the safety principles, installation and operation of hydraulic equipment. The points marked with the following symbols throughout this text are of paramount importance.

	DANGER	This symbol indicates the possibility of damage to health. Special attention and care are required for any procedures that could result in injury or death due to improper design or non-compliance with the given conditions.
	CAUTION	This symbol indicates the possibility of product or equipment damage. Special attention is needed for any procedures that could result in product or equipment damage due to improper design or non-compliance with the given conditions.
	NOTE	This symbol indicates operating procedures or other information important for the proper product functioning.

## 2. General technical information

### 2.1. Cleanliness of working fluid



**Minimum cleanliness class of working fluid 21/18/15 acc. to ISO 4406** (at operating pressure from 160 to 210 bar) is required for the use of our products. It must be not forgotten that the demands on fluid cleanliness increase together with the equipment operating pressure. For example, fluid cleanliness 19/16/13 acc. to ISO 4406 is recommended for the operating pressure 350 bar. The fluid must not contain any abrasive particles (e.g. quartz grains or other abrasive materials) causing excessive wear on parts. Poppet type valves, pilot operated valves and proportional valves are particularly sensitive to impurities which can easily cause the loss of functionality. Effective filtration with filter fineness between 5 and 12 microns ( $\beta=200$ ) is recommended to be included in the circuit.

### 2.2. Working fluids

Our products are intended in particular for working fluids based on mineral oils of the power class **HM, HV acc. to ISO 6743/4**. Before using other fluids, e.g. hardly inflammable (ISO 6071) or ecological fluids, consult the manufacturer. The main issue is to verify the mutual compatibility of the applied sealing material and the working fluid.

### 2.3. Temperature and viscosity of working fluid

The temperature range of the working fluid is generally dependent on the applied seal material and whether the valve is operated by a solenoid. Kinematic viscosity is significantly influenced by temperature and its range should be **between 10 and 500 mm<sup>2</sup>s<sup>-1</sup>**. It is recommended to keep the working temperature in the range of 40 °C to 50 °C, for the following reasons:

- › chemical degradation of the working fluid begins at a temperature higher than 40 °C
- › pressure energy transfer gets worse at a high temperature and low kinematic viscosity
- › rubber seals are damaged at a high temperature (> 100 °C) and they must be replaced by Viton seal
- › pumps and filters are overloaded at a low starting temperature and high fluid viscosity, i.e. the bypass check valve of the filter is open.

Group of products	Working fluid temperature	
	NBR seal	FPM (Viton) seal
Valves without solenoids	-30 °C up to +100 °C	-20 °C up to +120 °C
Valves with solenoids	-30 °C up to +80 °C	-20 °C up to +80 °C

Group of products	Viscosity range
Valves without solenoids	10 up to 500 mm <sup>2</sup> s <sup>-1</sup>
Valves with housing and solenoid	20 up to 400 mm <sup>2</sup> s <sup>-1</sup>
Built-in valves with solenoid	10 up to 500 mm <sup>2</sup> s <sup>-1</sup>

## 2.4. Working environment

### 2.4.1 Ambient temperature

The working environment temperature for solenoid operated valves should not exceed the maximum allowable temperature (usually 50 °C) due to the increase in winding resistance and the decrease in coil output power. There are no limit temperatures for the valves not operated by solenoids, however, the temperature significantly affects the working fluid viscosity and the seal material. Some built-in solenoid operated valves are designed for higher ambient temperature (80 °C) because they are expected to work near heat sources, e.g. combustion engines. Placing the hydraulic circuit into an enclosed space can result in a critical temperature rise. If the hydraulic system cooling through heat convection and radiation is not sufficient, a cooler with sufficient cooling capacity will have to be connected to the system.

Group of products	Ambient temperature
Valves without solenoids	unspecified
Valves with solenoid	-20 °C up to +50 °C
Built-in "high performance" valves	-20 °C up to +80 °C

### 2.4.2. Cleanliness of working environment

Protect the working fluid from ingress of particulate pollutants, especially when filling the tank of hydraulic system with fluid. The tank must be fitted with the filter of fineness between 2 and 3 microns.

### 2.4.3. Potentially explosive atmospheres

The components with ATEX and IECEx certifications meeting the demands of Directive EU 2014/34/EU or regional legal regulations may be used for potentially explosive atmospheres (mines, environments with flammable and explosive vapors and gases, operations with high dustiness).

### 2.4.4. Corrosion protection

The steel and cast iron parts are zinc-coated or phosphated. Climate resilience is verified by the accredited laboratory using the salt spray test (NSS) acc. to ISO 9227. Detailed information on the basic and supplementary surface treatment can be found in the catalogs.

Designation of surface treatment	Applied technology	Climate resilience in NSS (ISO 9227)
A	zinc coating Fe/Zn	min. 240 h
B	zinc coating Fe/Zn	min. 520 h

### 3. Overview of products

#### 3.1. Valves - divided into groups

Hydraulic valves are components used for the control of hydraulic circuits.

##### A. Valves depending on the connection into the circuit

###### Valves with housing

These valves are intended for a subplate mounting. Their port outlets are positioned on only one connecting surface. The mounting surface of given size (Dn) is usually standardized acc. to ISO 4401. The directional control valve is a typical example of such a valve.

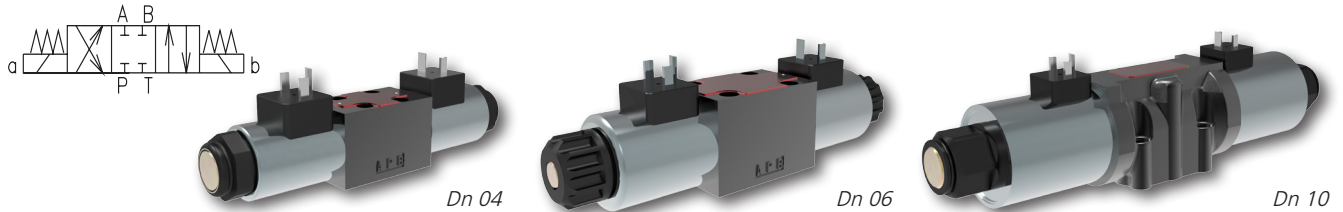

###### Screw-in cartridge valves

The valve housing is replaced by the steel sleeve. This type of the valve is designed for the mounting in a manifold or a modular plate. The connecting thread corresponds to the UNF standard or it is of metric type.

So-called slip-in valve is a special valve without a connecting thread.

Its position is secured by the steel flange and the screw after slipping into the cavity. These simplified valves are designed in particular for mobile applications without demands on high pressures and flow rates. They are characterized by a favorable price.

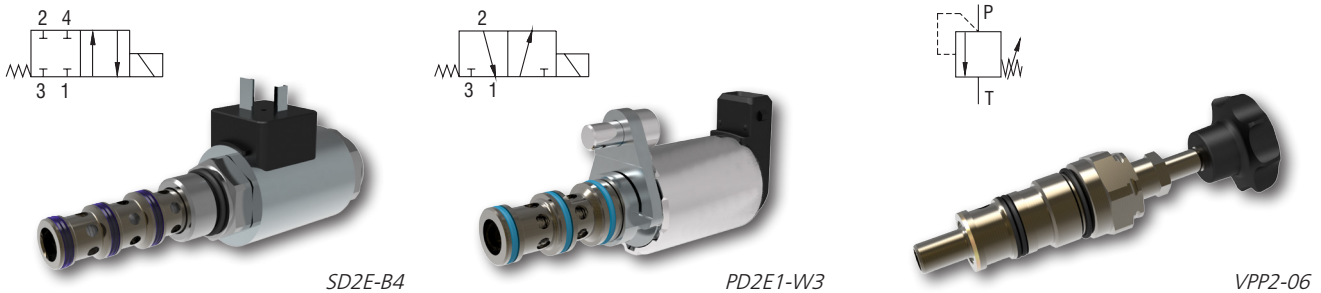

###### Valves built into modular plates

Modular plates equipped with through ports are intended for a vertical or horizontal stacking assembly. The mounting surface of given size (Dn) is usually standardized acc. to ISO 4401. Modular plates are combined into a single unit using studs. The maximum number of assembled plates is limited by the maximum stud lengths. Stacking assembly of modular plates enables the creation of very sophisticated hydraulic circuits. The big advantage of this solution can be seen in the flexible connection design.

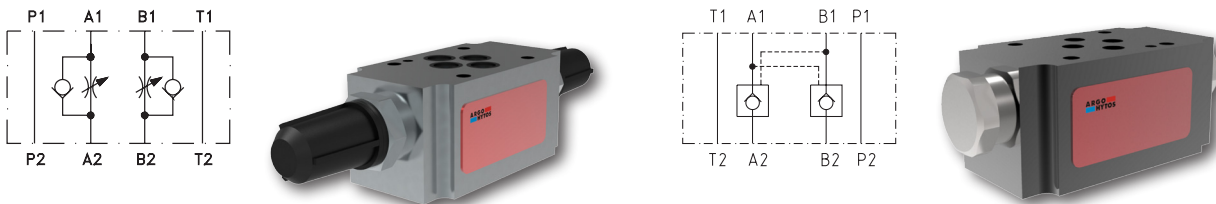

Restrictor valve with reverse flow check 2VS3-06

Double pilot operated check valve 2RJV1-06

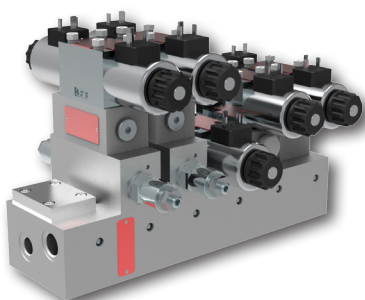

Manifold with valves placed in modular plates used for the vertical stacking assembly

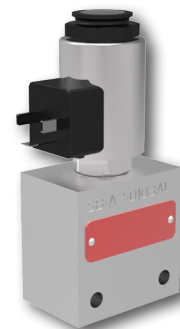
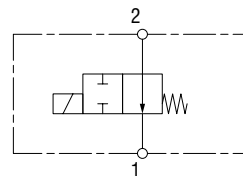

2-way, screw-in cartridge directional control valve SD2E-A2 in SB manifold used in an in-line design

###### In-line valves

These valves have the outlets with connecting threads, allowing them to be connected to the line. The screw-in cartridge valves can be connected to the line after their installation onto a manifold.

## B. Valves depending on the control process

### Directly operated valves

The control element (spool or poppet) of direct-acting valves is directly controlled by the operating element, e.g. solenoid. The valve power is limited by hydrodynamic forces which act on the spool against the force of the operating element.

### Pilot operated valves

For pilot operated valves, only the valve pilot stage is operated by the operating element and the main stage (spool, poppet) is operated hydraulically. It allows control of higher hydraulic powers. The valves are equipped with the orifices necessary for the control, however, these small openings are sensitive to contamination of the working fluid.

## C. Valves depending on the function in the circuit

### 3.1.1. Valves for fluid flow direction control – directional control valves

These valves allow the direction change of fluid flow or its blocking. They are designed to stop the actuator or control its movement direction.

#### Spool type directional control valves with housing

The precision-ground, hardened steel spool as a control element is shifted in the hole of the cast iron housing. The spool interconnects the ports mutually and closes the prefilled ports. In the basic position, the spool is held by the force of the return springs. There are a lot of ways to operate the spools of directional control valves, such as hand lever, foot switch, mechanical cam or eccentric piece, or even hydraulically or pneumatically. However, they are mostly commonly controlled by a solenoid.

Overview of the spool symbols is given in the catalog. For other possible interconnections consult the manufacturer.

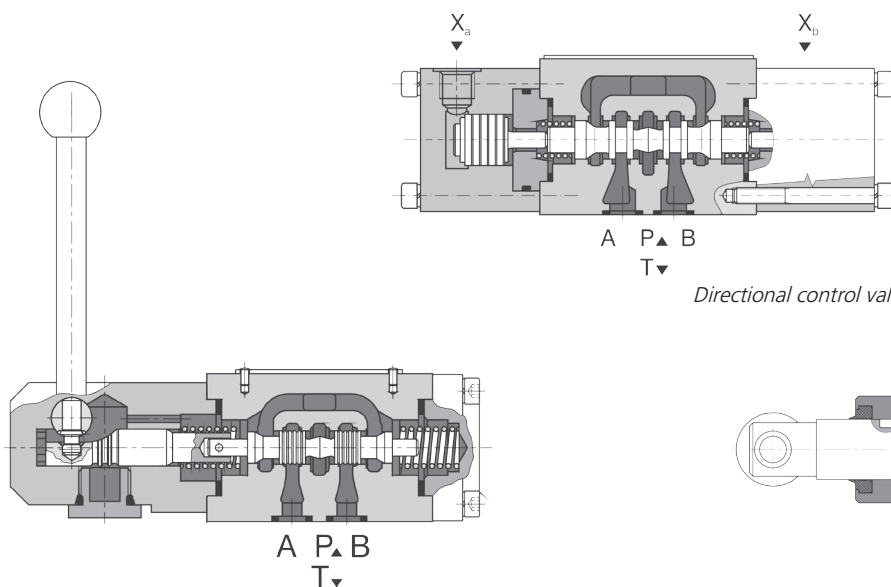

*Directional control valve - spool operated hydraulically (RPH2-06)*

*Directional control valve - spool operated manually (RPR3-06)*

*Directional control valve - spool operated by a cam (RPK3-06)*

#### Bankable directional control valves of size Dn 03

These valves are the smallest directional control valves of size Dn 03. The spool is incorporated in the modular plate for the horizontal stacking assembly. The directional control valve consists of a supply unit with a pressure relief valve and 1 to 8 bankable directional valves. Ports P and T are common for all sections. Maximum flow rate through one directional control valve is 20 l/min. Their advantages are small dimensions, flexibility of use and compactness.

The bankable directional control valve is also the basic construction element for the modular valve assembly RPEK1-03/B.

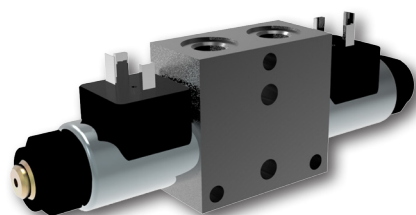
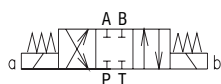

*Bankable directional control valve RPEK1-03*

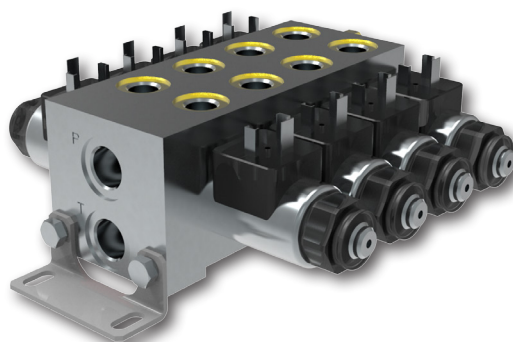

*Monoblock directional control valve RPEK1-03 with 4 sections*

**Solenoid operated valves with housing - sizes Dn 04, 06, 10**

The 4-way valves with one operating solenoid (2-position) or two solenoids (3-position) manufactured in three sizes.

Size of directional control valve	Maximum pressure	Maximum flow rate
Dn 04	320 bar	40 l/min
Dn 06	350 bar	80 l/min
Dn 10	350 bar	140 l/min

For all three sizes, valves operated by two solenoids are available with spool detent assembly. It allows the change of spool position applying a short-time pulse switching of the solenoid. For dangerous machines, such as presses or molding machines, the directional control valves of sizes Dn 06 and Dn 10 are used with the non-contact spool position sensor of type PNP. Information on the spool position is necessary for the machine safety control system.

It is possible to supply directional control valves with CSA certification (Canadian Standard Association) on request.

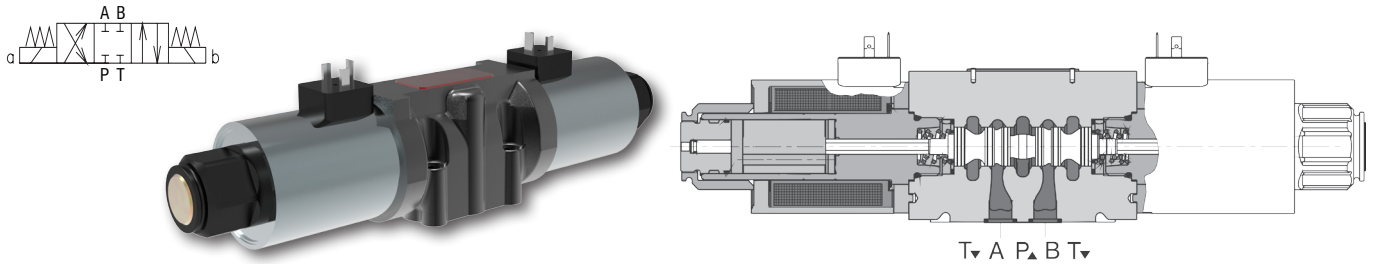

4-way, 3-position (4/3) directional control valve operated by two solenoids



- › For directional control valves with two solenoids, one solenoid must be deenergized before the other solenoid can be charged.
- › For directional valves with detent assembly, the solenoid switching time shall not be less than 60 ms to allow a secure shift of the spool.

**Directional control valves of sizes Dn 10, Dn 16 and Dn 25 with pilot valve**

They are designed to control high flow rates up to 150 l/min (Dn 10), 300 l/min (Dn 16) or 600 l/min (Dn 25). The pilot valve is the directional control valve of size Dn 06 used for distribution of the fluid under pressure toward spool faces of the main valve. While the spool of the pilot valve is operated by the actuating solenoids, the main valve spool is operated hydraulically. There are versions with internal or external supply to the pilot valve.

Another option is to operate the main valve spool hydraulically by external ports without any pilot valve. The high pressure version, offered as an option, has the main valve housing made of cast iron with the increased strength and pressure resistance up to 420 bar. For example, this version is suitable for presses characterized by pressure peaks at reaching the tool contact point.

The catalog of the products includes also control options of spool switching times of the main valve, flow restrictions in both flow directions by setting the stroke limiter control option of the main valve.

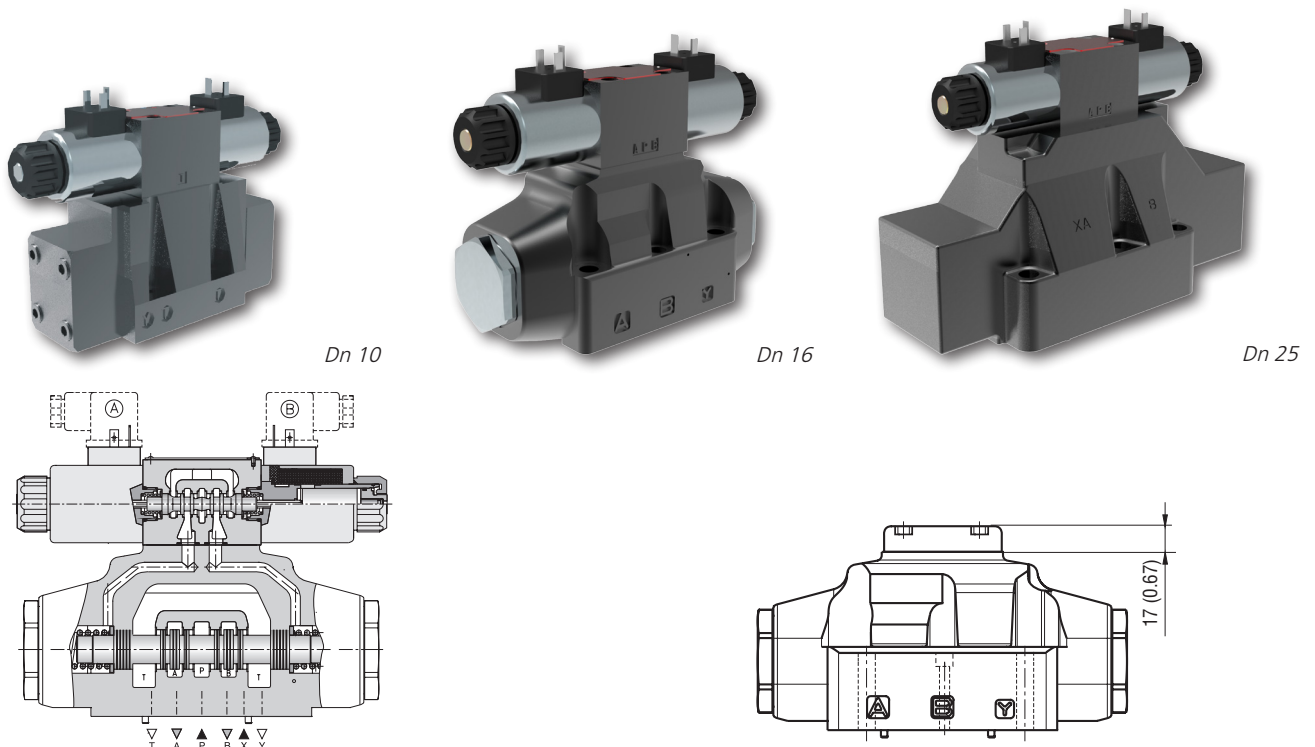

Directional control valve of size Dn 16 with a pilot valve of size Dn 06 operated electromagnetically. Port X is used for external supply of the pilot valve. Port Y serves to drain the oil from the pilot valve.

Directional control valve of size Dn 16 with the spool of the main valve operated externally by ports X and Y. Mounting surface for the pilot valve is closed by the blanking plate containing T line bridges.

**Screw-in cartridge valves - spool and poppet type**

**Screw-in cartridge directional control valves, spool type**

The spool shifts in the steel sleeve and opens or closes radial holes in the sleeve. The 2-position 2-way valves, 3-way valves or 4-way valves are manufactured in two sizes. The valves with the connecting thread 3/4-16-UNF correspond to size Dn 04 owing to their flow rate. Similarly, the valves with the connecting thread 7/8-14-UNF correspond to size Dn 06.

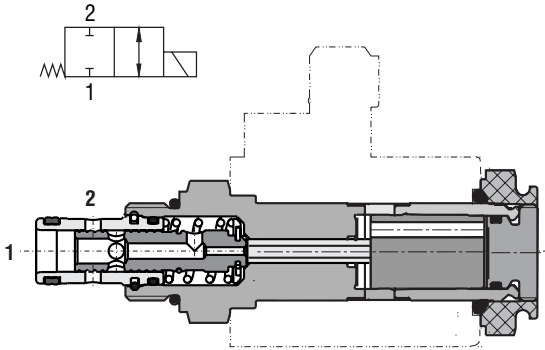

*Screw-in cartridge, 2-way directional control valve, spool type*

**Screw-in cartridge poppet valves**

The spool is here replaced by a hardened cone closing the fluid flow by slipping into the poppet sealing edge. The main advantage of poppet valves is very low leakage. These valves are more sensitive to contamination of the working fluid. They are manufactured as 2-position, 2-way valves, directly or pilot operated.

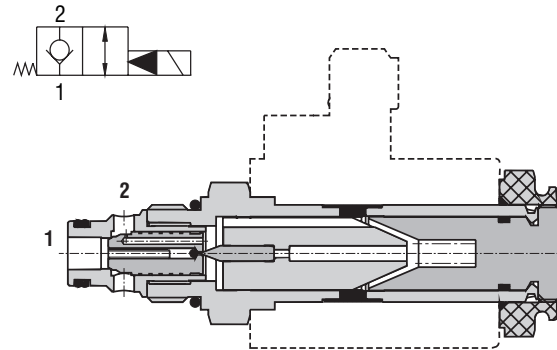

*Screw-in cartridge poppet valve, pilot operated*

**"High performance" and "Lightline" versions**

While valves of the "high performance" series are designed for high hydraulic power, the "light line" series is suitable for low power applications. Lower power allows the integration of smaller solenoids, and justifies therefore a lower price. The design quality of both series remain the same.

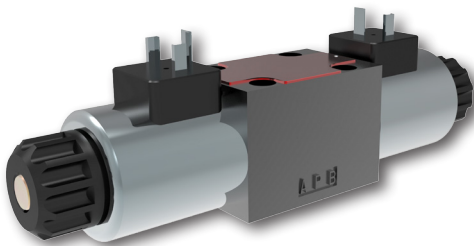

*Spool type directional control valve with housing RPE3-06*

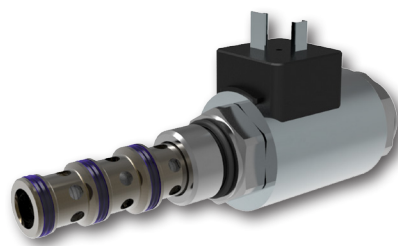

*Screw-in cartridge, spool type directional control valve SD2E-B4*

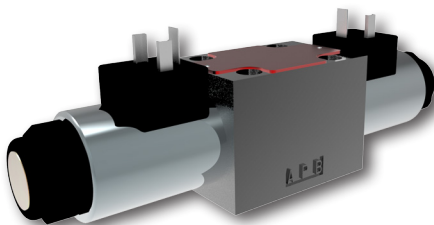

*Spool type directional control valve with housing RPEL1-06 - "Lightline" version*

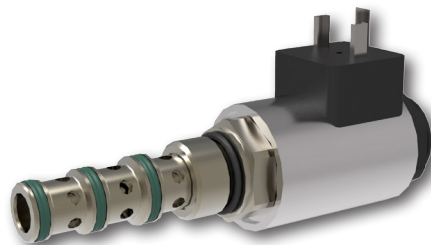

*Screw-in cartridge, spool type directional control valve SD2E-B4/L - "Lightline" version*

**Priority valves**

Spool type valves operated hydraulically for ensuring a specified sequence of functions in a hydraulic circuit. Under the condition that the pressure in the control circuit, acting on the spool face area, reaches the value set by spring compression, the spool is shifted and the parts of the circuit are connected.

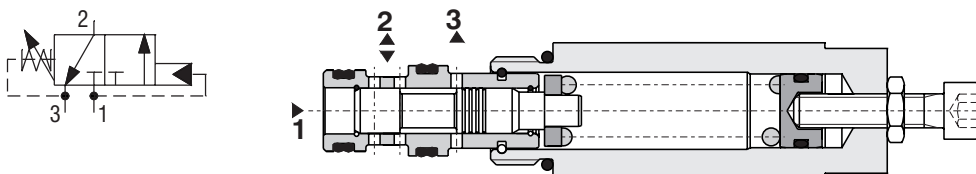

*Priority valve SS4A-A3, operated hydraulically*

**Hot oil shuttle valve for closed hydrostatic circuits**

Especially for heavy vehicles (such as quarry damper) with the demands on a low speed and high torque on wheel axes, the closed hydrostatic circuit with variable displacement pump and reverse hydraulic motors are often used to drive the wheels. Such systems use a relatively small volume of the working fluid while high power is transmitted. This leads to a rapid heating of the fluid and its portion must be drained from the low pressure branch of the system toward the cooler and back to the tank through the filter. Afterward, the cooled and filtered fluid is refilled to the low pressure branch by a small filling pump. Screw-in 3-way valve, operated hydraulically, allows to drain the fluid from the low pressure branch depending on the flow direction (acc. to movement sense of the actuator).

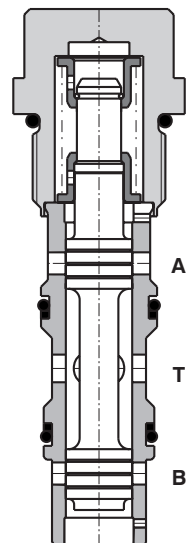
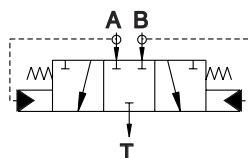
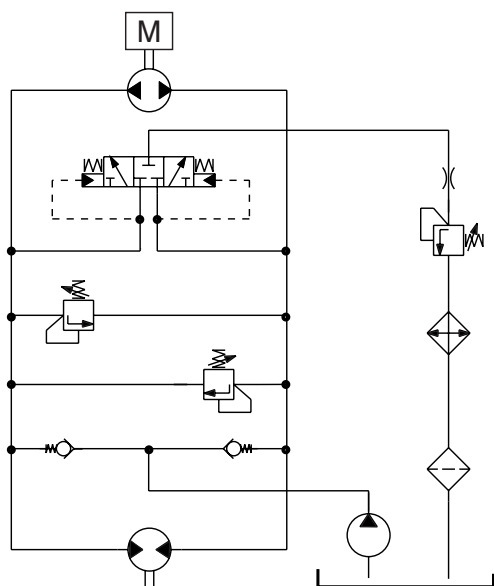

SD2H-LA3

### 3.1.2. Check valves

Poppet type valves allow working fluid flow only in one direction. In the reverse direction, the working fluid pressure acts on the hardened cone or ball towards the valve sealing edge. The resting position of the cone or ball is enforced by a spring of low stiffness. The check valves fitted with a stronger spring are sometimes used as back pressure valves creating a slight overpressure, or simple pressure relief valves.

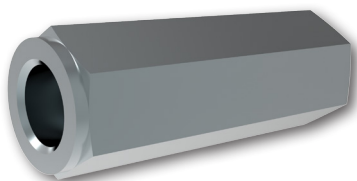

Check valve VJ3 used for in-line mounting

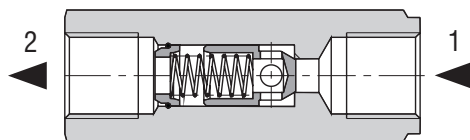

### Pilot operated check valves

These check valves are opened in the reverse direction or closed in the free direction mechanically using an auxiliary piston actuated by the fluid pressure from the second branch of the actuator. Pilot operated check valves, opened in the reverse direction, are pilot operated check valves used to secure the position of a load. They are integrated as screw-in valves into modular plates. For Dn 06 and larger sizes, the valves are manufactured with the decompression valve reducing the pilot pressure needed to open the valve completely and so dampen the pressure shocks during the opening.

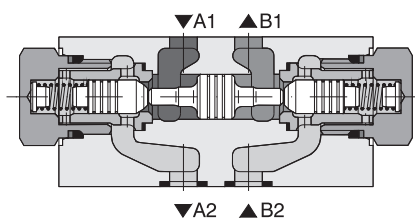
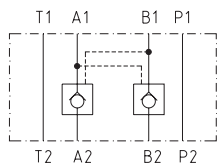

Double pilot operated check valve (2RJV1-06) built into modular plate

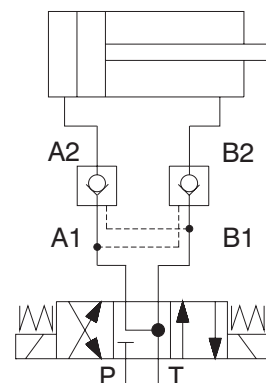



### Load shuttle valves

Poppet type valves securing automatically certain logic functions in the circuit. The valve shown in the figure connects port X with port A or B depending on the higher pressure.

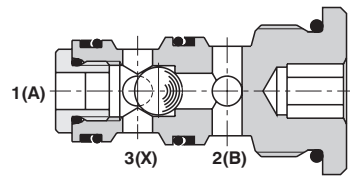
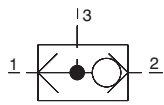

3-way load shuttle valve LV1-063 used as screw-in valve

### 3.1.3. Pressure valves

The pressure valves are designed for the pressure control in the circuit and thus for the force control on the actuator - the force acting on the piston rod of the hydraulic cylinder or the torque on a hydraulic motor shaft. They are manufactured as pilot operated and directly operated valves.

#### Pressure relief valves

2-way valves operated by inlet pressure are connected to the circuit parts in parallel and protect them against overpressure. If the pressure in the circuit exceeds the adjusted value of valve cracking pressure, the valve will open and the fluid will be drawn to the tank. The valves have a relatively large pressure drop. Therefore, they should be used as pressure relief valves but they are not designed for the permanent pressure control in a circuit. The directly operated valves are equipped with suitable hydraulic damping to ensure the valve stability in the circuit. Moreover, the spring force increases when the valve flow rate increases.

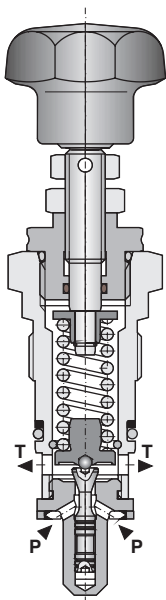

For the directly operated pressure relief valve, the force acting on the cone by the fluid under pressure is continuously compared to the adjusted spring force. (valve VPP2-06)

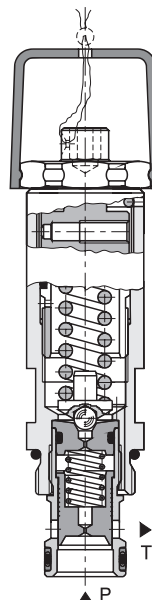

For the pilot operated pressure relief valve, the force of the fluid under pressure and the spring force on the control stage cone are compared. The control stage opening will cause a pressure imbalance of the main stage spool. It will lead to its shift and opening of radial holes of the steel sleeve, hence, the fluid will be able to flow in the direction P → T. (valve VPN1-06)



If the spring chamber is connected to port T, any pressure change in this port will cause a change in the adjustment of the valve cracking pressure. If the pressure changes significantly in port T, it is recommended to use a valve with external drainage of the fluid from the spring chamber.

#### Pressure relief valves with certification for pressure equipment (PED)

Certified valves are intended for the protection of circuits with dangerous elements, such as pressure tanks of hydraulic accumulators. They must be reliable as it concerns their functionality. The certification meets the requirements of directive 2014/68/EU. The valves are offered in two versions - without any adjustment or with adjusted cracking pressure and adjustment screw secured using a lockwire.



According to the requirements of the standard ISO 4126-1, the system pressure at the valve opening may overshoot no more than 10 % of the adjusted cracking pressure. Therefore, the usage of such valves is limited by maximum flow rate.

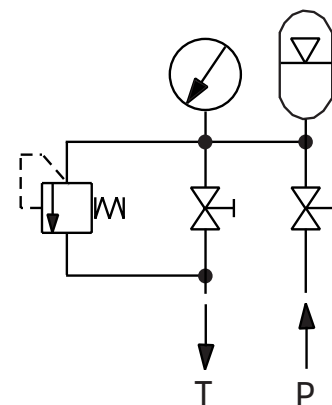

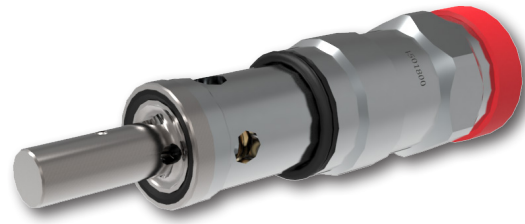

Certified valves (PED) SR1A-B2 and VPP-R-16

**Pressure reducing-relieving valves**

These valves are controlled by the outlet pressure and they hold a constant pressure at the valve output. These 3-way pressure reducing-relieving valves provide two functions: pressure control (flow direction P→A) and circuit protection after the valve against pressure overload (flow direction A → T).

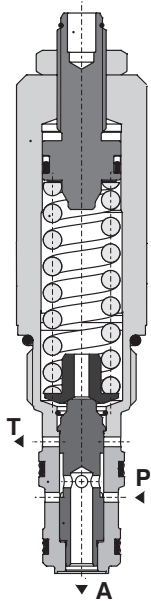

For directly operated reducing-relieving valves, the fluid flows toward the actuator P→A. If the pressure at the valve outlet rises (e.g. because of load increase on the actuator), the increased pressure will act on the spool face and shift it against the spring force. The radial input ports P start to close and the pressure in port A decreases due to a throttling of the flow. If any sudden significant pressure rise occurs at the valve outlet A, the spool will shift in such a way that the input ports P will be closed completely and Port A will be connected to the tank by the reverse branch T. Port A is unloaded to protect against overloading. (Example: valve SP2A-B3).

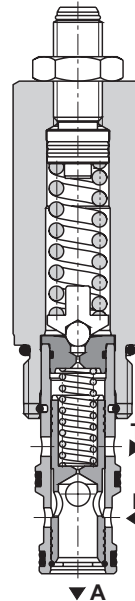
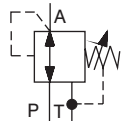

For pilot operated pressure reducing-relieving valve, the main stage spool is operated hydraulically using the pressure difference created by the control stage opening (Example: valve SP4A-B3).

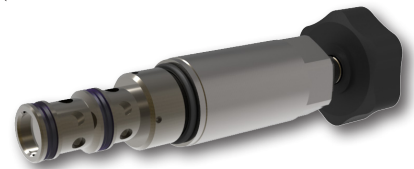
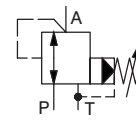

**Unloading valves**

Pilot operated pressure relief valves supplemented by the control stage adjustment using an external pilot. They are intended for specific applications in the circuits with accumulators where the accumulator is used as a pressure energy source for manual override, e.g. for brakes. The accumulator must be kept permanently in a full condition. If the accumulator is full, the valve will open and the fluid will be drawn to the other circuit part or back to the tank. To reduce the high pressure drop across the valve, the control stage is kept in the open position by the pressure signal from the accumulator circuit until the pressure falls below the given value (by about 15 %). Afterward, the valve is closed again and the accumulator is pressurized.

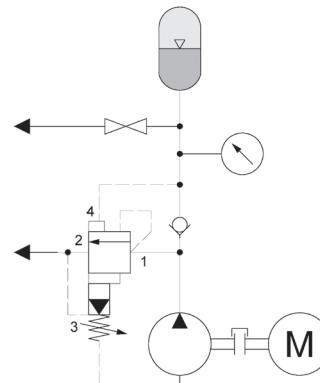

The fluid under pressure from the pump circuit enters the valve through Port 1. Depending on the pressure in the accumulator, this fluid can be drawn to the other circuit part or back to the tank through Port 2. Fluid under pressure from the accumulator circuit is brought into the valve through Port 4. This fluid acts on the auxiliary piston which keeps the control stage open mechanically in the specified pressure range inside the accumulator (100 % to 85 % of the pressure adjusted by the valve). The fluid is drained from the control stage through Port 3. Therefore, the adjustment of the valve cracking pressure is independent of pressure changes in Port 2. (Example: valve SUD-6A)

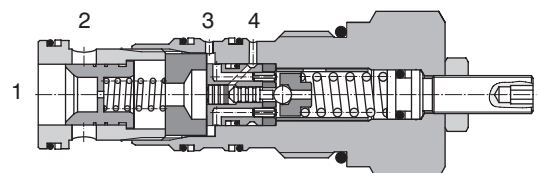
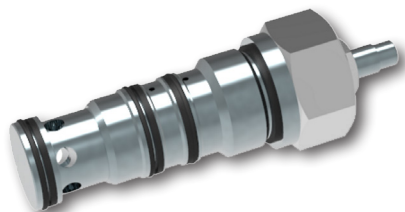
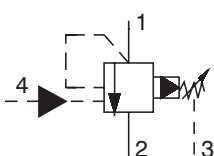

### 3.1.4. Overcentre valves

These pressure valves are designed for the controlled lowering of a load if the load acts negatively, i.e. in the direction of the actuator movement. The negatively acting force accelerates the actuator movement (piston in the cylinder or shaft rotation of hydraulic motor). It could lead to a loss of control over the system and consequently to an accident. The valves are designed as directly operated pressure relief valves with a bypass check valve and the valve opening using an external pressure signal taken from the input branch of the actuator. The valve provides the controlled load lowering, load positioning when the system stops and blocking the actuator movements, if there is a pipe burst. The valves are mounted directly onto the actuator or in its close proximity. The valves are offered in various design options.

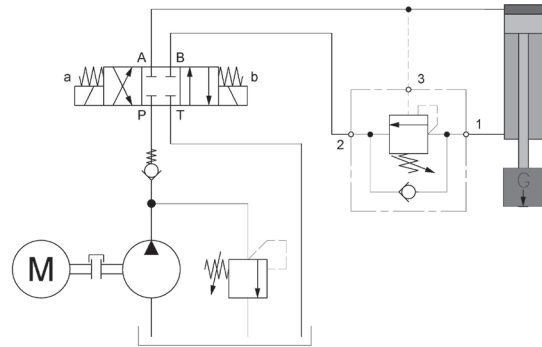

During the lowering of the load on cylinder piston rod, there is the influence of gravity leading to an acceleration of the piston movement. This decreases the pressure in the space above the piston cylinder. At the same time, the pressure drops in the valve inlet 3. The pressure in this port controls the opening of the valve cone and interconnection of cylinder outlet and return line to the tank. The pilot pressure drop (3) causes the poppet to move in the closing direction and so to a reduction of flow rate from the cylinder's rod-side chamber back to the tank. This slows down the piston movement. If the supply line breaks, the system pressure will drop, the valve will close and piston movement will be stopped. During the reverse movement of the cylinder piston, the fluid flows through the built-in bypass check valve (Example: valve SOP5A-Q3).

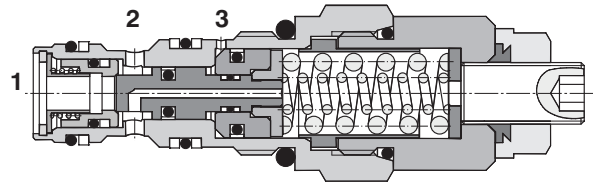
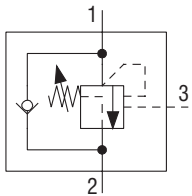

### 3.1.5. Flow control valves

They are intended for actuator speed control, i.e. shift speed of a cylinder piston or the rotational speed of a hydraulic motor. The throttle valve changes only the cross-sectional flow area. In order to stabilize the actuator speed, independently of the pump supply and external forces on the actuator, the valve must be equipped with a compensation for the pressure difference. For 2-way pressure compensation, the valve inlet pressure is controlled based on the outlet pressure by throttling the flow. For 3-way pressure compensation, the regulation is achieved by draining the fluid portion back to the tank. The pressure difference of the valves determines the pressure generated by the compensator spring. For valves with pressure compensator, the flow rate through the valve can be adjusted either by the change of cross-sectional flow area or by pressure difference adjustment using the spring preload.

$$Q = S \cdot \mu \cdot \sqrt{\frac{2 \cdot \Delta p}{\rho}}$$

$$\Delta p = p_1 - p_2 = \text{const.}$$

- Q ... flow rate of the valve
- S ... cross-sectional flow area
- $\mu$  ... hydraulic coefficient dependent on the type of fluid flow
- $\Delta p$  ... pressure difference (inlet pressure – outlet pressure)
- $\rho$  ... working fluid density dependent on temperature

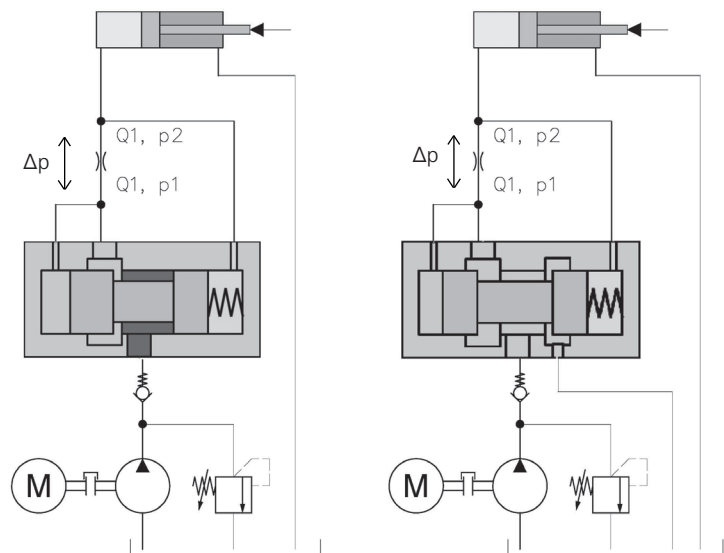

2-way pressure compensator

3-way pressure compensator

The pressure compensators stabilize the pressure difference and flow rate behind the valve independently of the inlet and outlet pressures of the valve.

Screw-in cartridge flow control valves with 2-way (SF22A-B2) and 3-way (SF32A-B3) pressure compensator

Screw-in cartridge valve SF32A-K3 designed for flow control using a 3-way pressure compensator and the cross-sectional flow area control.

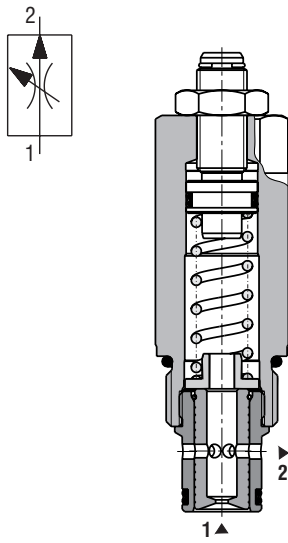

SF22A-B2

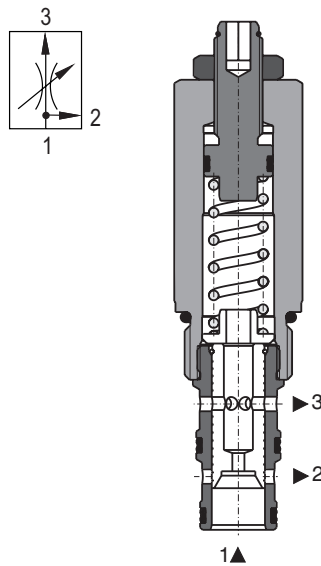

SF32A-B3

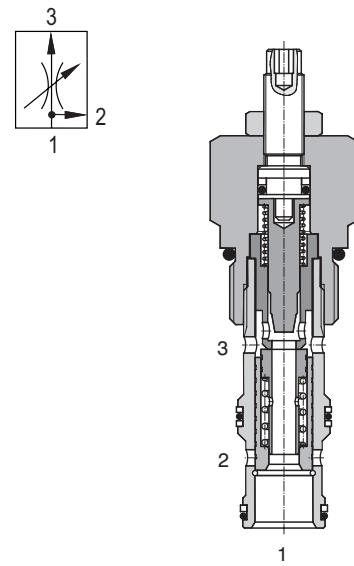

SF32A-K3

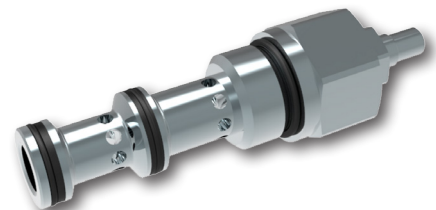
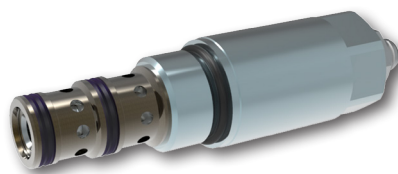
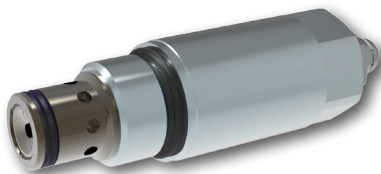

**Flow dividers**

Divider valves are one way to divide fluid flow from the pump to more actuators at specified rate, independently of their different loads. Accuracy of division is generally between 2 % and 10 %. If the actuators are hydraulic cylinders, it is recommended to use cylinders with larger piston diameter, where the specified inaccuracy results only a small difference in stroke. These built-in valves contain a steel sleeve in which two spools of 2-way pressure compensators can shift. These spools are loosely coupled in a mechanical manner and they mutually affect their positions.

The flow divider and combiner valve with two loosely connected spools (in a mechanical manner) of pressure compensators. The fluid enters Port 1 radially. Ports 2 and 3 are outlets toward the actuators.

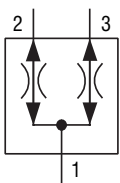

SFD2F-B4

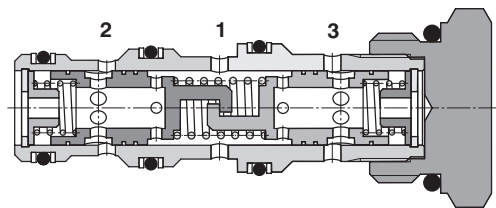

### 3.1.6. Proportional valves

Unlike conventional valves, they adjust the specified parameter in the whole range of values. Precise adjustment requires also improved design of the valves, therefore the price of proportional valves is higher. The control electronics are an integral part. They are either part of the valve ("on board") or a control card is placed in an appropriate electric cabinet. The electronics are powered by 12 or 24 V DC. Modern valves are controlled by pulse width modulation signal (PWM). There are 3 types of the control:

- › without feedback
- › with internal feedback - with a spool position sensor
- › with external feedback - with the sensor signal of controlled parameter in the circuit

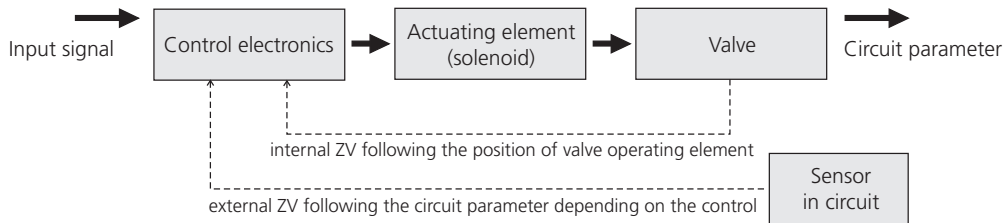

#### Proportional directional control valves

These valves are used to fine adjust flow rate. Furthermore, versions with two solenoids may be used to change flow direction. The valves are manufactured in sizes Dn 04, Dn 06 and Dn 10. Each size has two or three flow rates depending on the shape of the metering edges on the spool. For load-independent flow control, it is necessary to stabilize the pressure difference on the directional control valve using the pressure compensator. The valve parameters are defined for a pressure drop of 10 bar. The older versions of proportional directional valves use analog electronics in an open loop configuration. Updated versions use digital electronics and feedbacks.

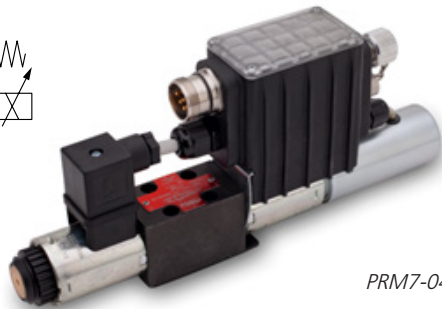
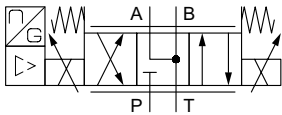

Proportional directional control valves of sizes Dn 06 and Dn 10, controlled by a digital electronic unit, capable of working with internal and external feedback or their combination.

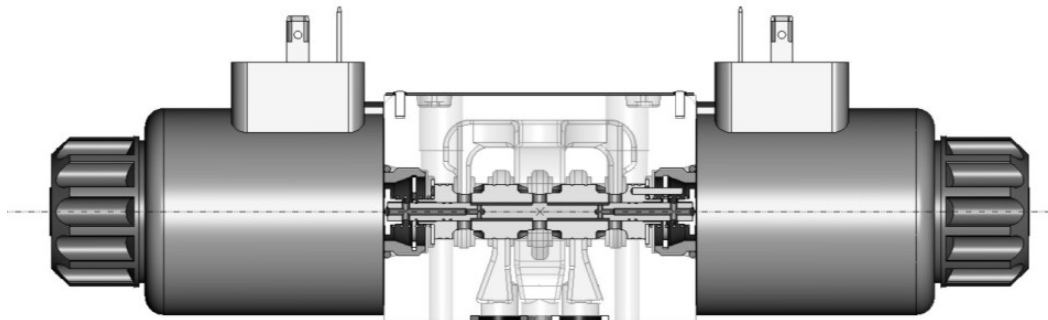

The pilot operated directional control valve PRM8 of size Dn 06 is characterized by high performance (350 bar, 130 l/min). Its control spool is operated by the solenoids and the main spool is operated hydraulically.

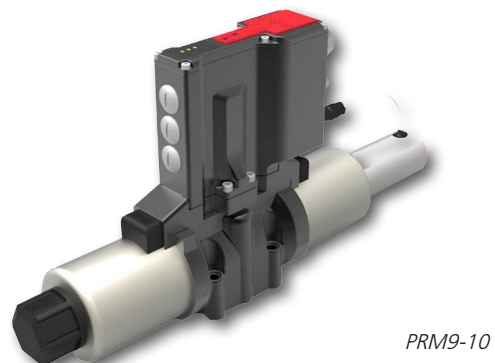

The proportional directional control valve PRM9 (sizes Dn 06 and Dn 10) is a modern proportional valve with hydraulic parameters optimized by mathematical-physical models, good dynamics and an intelligent electronic control unit capable of communication via CAN bus.

**Proportional pressure valves**

This type of pressure relief valve serves to fine adjust the maximum pressure in the circuit. Pressure reducing-relieving valves on the other hand are intended for the fine pressure adjustment after the valve - directly on the actuator. The proportional pressure valves allow remote pressure control by electrical signal. It is recommended to use the digital control electronics in the form of DIN connector (EL6).

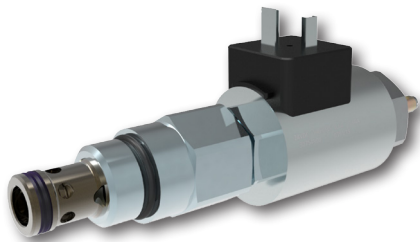
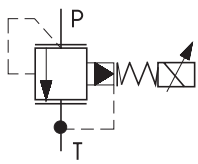

SR4P2-B2

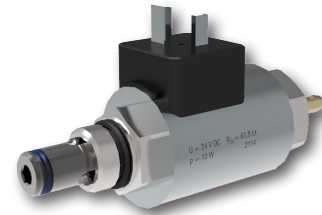
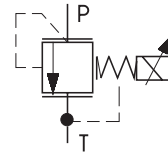

SR1P2-A2

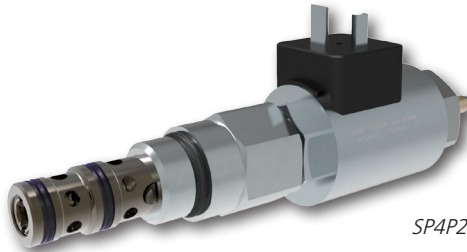
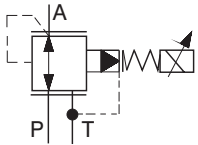

SP4P2-B3



EL6

The pilot operated pressure proportional valve with 7/8-14 UNF thread, 2-way pressure relief valve SR4P2-B2 and 3-way pressure reducing-relieving valve are applicable for pressures up to 350 bar and a flow rate up to 60 l/min. Both valves have the same pilot stage fitted with 3/4-16 UNF thread, usable as a directly operated pressure relief valve with flow rate up to 1.5 l/min. The miniature external electronics EL6 in the form of DIN connector is used to control the valves.



To reach reliable and stable function, the valve must be vented properly using a screw placed at the end of the solenoid actuating system.



Remember that the spring force is replaced by the solenoid force. No pressure is created in the circuit when the solenoid is switched off. This is functionally different from the valves operated mechanically by the spring. For applications with the reverse function as a necessity, the proportional pressure valves with inverted flow characteristics were developed - the higher the control signal, the lower the pressure.

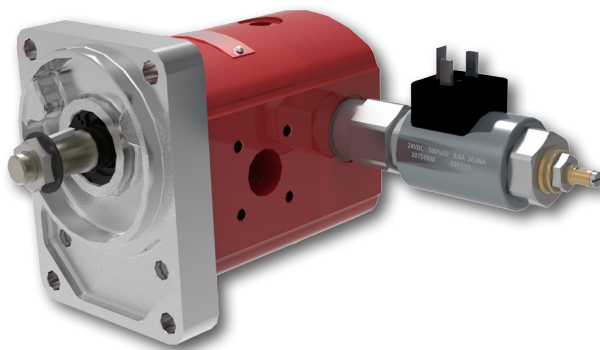

The hydraulic drive and the rotation speed control of a cooler fan (Fan Drive) together with a valve SRN4P1-B2 with the negative characteristic to achieve the optimal constant temperature of the combustion engine.

System pressure [bar]

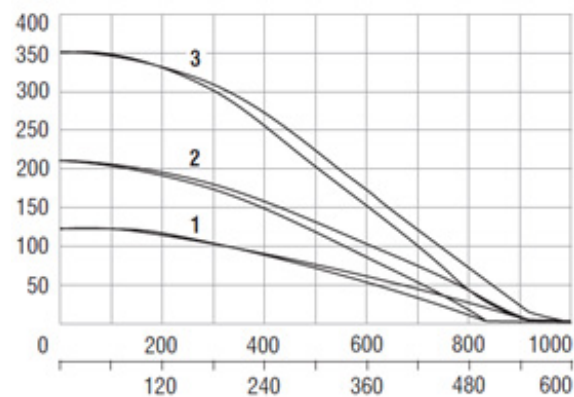

Control signal [mA] – 12 / 24 V DC

**Low-pressure proportional pressure reducing valves**

The Screw-in / slip-in cartridge valves with an inlet pressure of up to 50 bar are specially designed for mobile applications where the system pressure varies between 20 and 30 bar. Pilot operated and directly operated versions are available. Pressure reducing-relieving valves in the slip-in version are in particular used for the control of gearboxes and clutches of mobile equipment. To cover the broadest range of applications, two types of valves with different port arrangements were developed - the first one with Port A in the axial direction and the second one with Port A in the radial direction located in the middle of the housing. The proven built-in valves PVRM of sizes Dn 06 and Dn 10 with metric thread belong to this group.

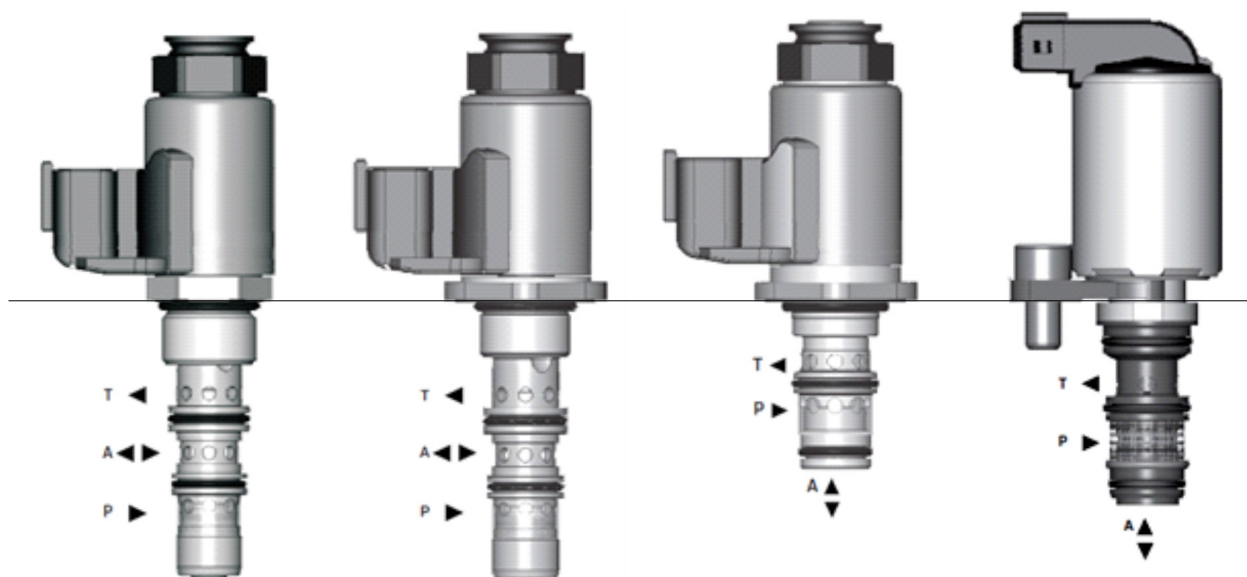

*Pilot operated reducing-relieving valve SP4P1-B4 with 7/8-14 UNF thread and valve PP4P1-Z3 in the slip-in version. Radial direction of Port A.*

*Pilot operated reducing-relieving valve SP4P1-ZA3 and directly operated Slip-in valve PP2P3-W3. Axial direction of Port A.*

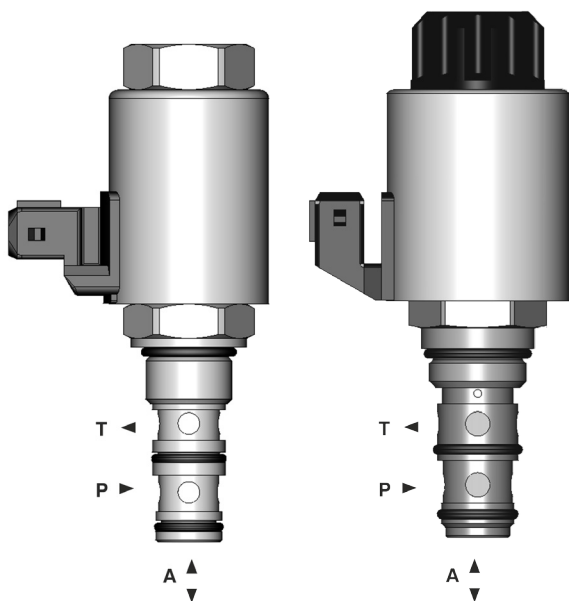

*Directly operated reducing-relieving valves PVRM1-063 and PVRM3-10 with a metric connecting thread.*

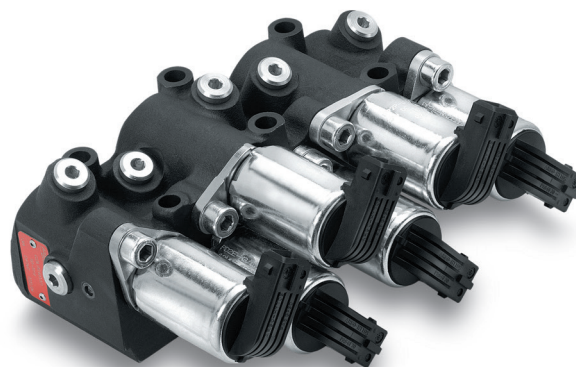

*Typical block for mobile equipments*

### 3.1.7. Explosion-proof valves

These valves possess the ATEX certification acc. to the directives 2014/34/EU and the IECEx certification. As the basic type of protection, the coil is embedded in the insulating material (m) with a high protection level (Mb, Gb, Db) for normal operation and estimated potential failures. Depending on the solenoid power and ambient temperature, the surface temperature is achieved in the following classes: T4 (max. 135 °C), T5 (max. 100 °C) and T6 (max. 85 °C).

Application areas of valves:

I. Mines with an explosive atmosphere of mine gas consisting mainly of methane

Group M2	The equipment remains switched off after the explosion.
----------	---

II. Explosive atmosphere of vapors and gases (chemical, petrochemical and gas industries, etc.)

Group IIB	Ethylene is a typical example of such gas.
Group IIA	Methane is a typical example of such gas.

III. Explosive atmosphere of dust and particulate matter (mills, lime works, textile industry, etc.)

Group IIIC	Conductive dust (Specific resistance $\rho \leq 10^3 \Omega m$ )
Group IIIB	Non-conductive dust
Group IIIA	Particulate matter (e.g. fibers)



Valves powered with alternating voltage are provided with a built-in rectifier embedded in the insulating material. Therefore, these valves can be delivered only with mounted supply cable of normal length 3 m or 8 m.



If the ATEX solenoid is used separately without the hydraulic part of the valve, the solenoid surface temperature will increase above the specified value due to reduction of the heat transfer surface area. The elevated surface temperature is one of the sources of explosion.

The following valves are available in the ATEX version:

4/3, 4/2 directional control valve with housing - size Dn 06	RPEX3-06
4/2, 3/2, 2/2 screw-in cartridge valve with 7/8-14 UNF thread, spool type	SD2EX-B2, SD2EX-B3, SD2EX-B4
2/2 screw-in cartridge poppet valve with 7/8-14 UNF thread, pilot operated	SD3EX-B2
3/2 screw-in cartridge poppet valve with 3/4-16 UNF thread, direct-acting	SD1EX-A3
4/3, 4/2 directional control valve with pilot valve ATEX	RNEXH1-10, RNEXH5-16, RNEXH4-25

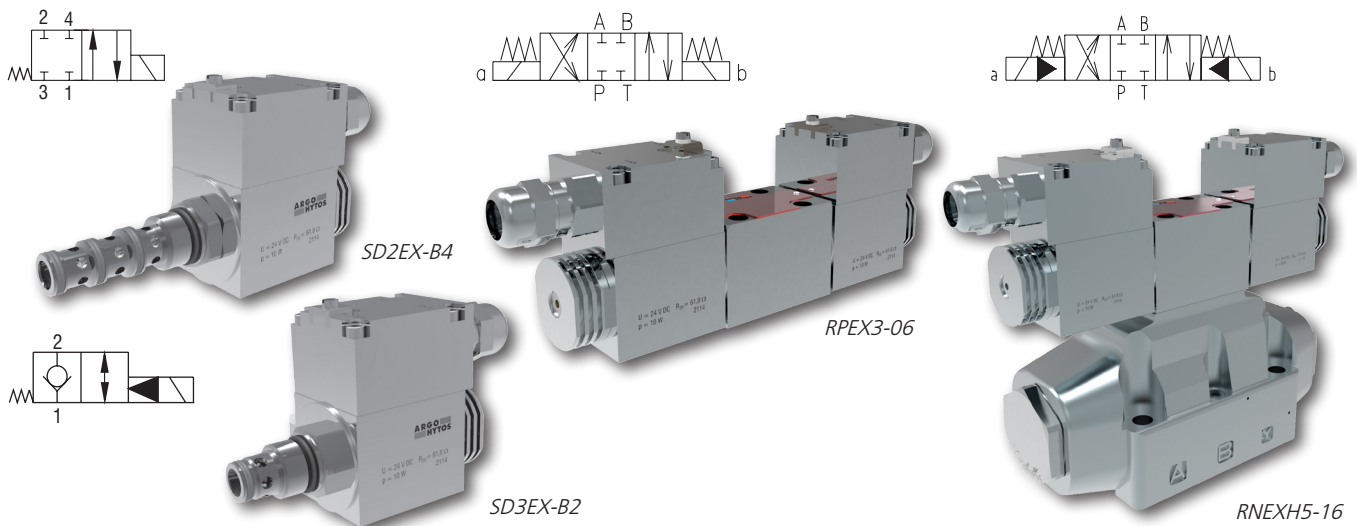

### 3.2. Actuating solenoids

They are used for electrically operated valves. The solenoid consists of two basic separable parts. A magnetic field acting on the armature of the actuating system is created by an electric current passing through the coil of the excitation system. The armature movement is transmitted by the pin to the spool or the cone of the valve. The first advantage of this design solution is that the connector may be positioned as desired by turning the excitation system around the longitudinal axis of the actuating system. The second advantage is the easy replacement of the excitation system after loosening the nut without a need to dismount the hydraulic section.

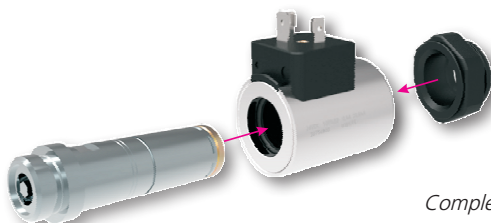

Complete solenoid consisting of actuating system, excitation system and tightening nut



### Sizes of coils

Number in the coil designation corresponds to outer diameter of the control system and inner diameter of the coil.

Coil designation	Basic application areas
C14	valves of size Dn 03
C19	valves of size Dn 04 and screw-in cartridge valves with 3/4-16 UNF thread
C20	valves of size Dn 06, reduced coil power (8 W)
C22	valves of size Dn 04 and screw-in cartridge valves with 7/8-14 UNF thread
C31	valves of size Dn 10

### Energizing the solenoid coils

The coils are powered with DC current. Magnetic flux excited by the coil is defined by Hopkinson's law:

$$\Phi [Wb] = \frac{U_M}{R_M} = \frac{I \cdot n}{L} \left[ \frac{Az}{H^{-1}} \right]$$

- $\Phi$  - magnetic flux [Wb]
- $U_M$  - magnetomotive force [AT]
- $R_M$  - magnetic resistance [ $H^{-1}$ ]
- $I$  - electric current [A]
- $n$  - number of coil turns
- $L$  - coil inductance [H]



The solenoid nominal power depends on electrical supply and winding temperature. It is important to maintain the specified values of the power supply ( $U_n \pm 10\%$ ) and the limit temperature for the working fluid and the surroundings. The coil resistance increases with higher temperature and the current passing through the coil decreases. Solenoid power and hydraulic power of the valve decrease acc. to Hopkinson's law. Copper wire of the coil winding belongs to the temperature class 200 (insulation temperature index  $\leq 200\text{ }^\circ\text{C}$ ).



The coils used with AC power supply are fitted with the rectifier placed in the connector or plug connector.

### Quenching diode (transient-voltage-suppression diode)

It is a semiconductor element connected between the outlets of the coil winding, which protects the electronics against any damage caused by peak voltage. This dangerous voltage is created by the induction during the magnetic flux change according to Lenz's law, i.e. when an inductive load (coil) is connected / disconnected in the circuit.

$$U_i = -\frac{\Delta\Phi}{\Delta t} = -L \frac{\Delta I}{\Delta t}$$

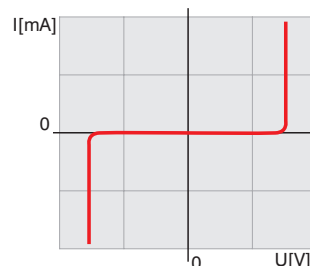
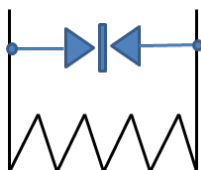

When the threshold voltage is exceeded, the quenching diode will open and the energy of overvoltage is converted to thermal energy.

### Connectors

The basic connectors used for coils are the following:

- › Connector DIN EN 175301-803-A (IP65)
- › Connector AMP JUNIOR TIMER (IP67)
- › Connector DEUTSCH DT04-2P (IP67)
- › Wire box
- › Loose conductors

### Manual override of valves

In case of power blackout or failure, it may be to manually shift the operating element in the valve to reach a safe position of the actuated mechanism.



The valves feature manual override, which is, however, only operable if the pressure in Port T does not exceed 25 bar.



Basic versions of the manual override using pin or push button placed in the protective rubber sleeve.

### Directional control valves operated by solenoid with spool manual override using hand lever

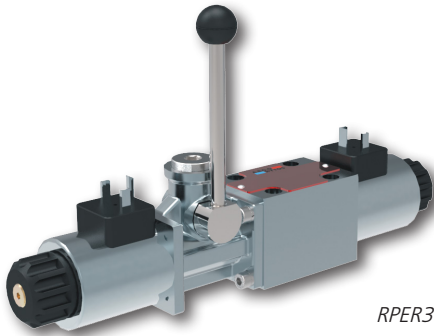

These special directional control valves are intended for applications requiring manual override that is usable up to a maximum allowable pressure in port T of 100 bar. The hand lever doesn't affect performance or functionality of the solenoid operated valve.

RPER3-06

### 3.3. Manifolds

Manifolds are hydraulic equipment parts used for interconnection of individual circuit parts. In particular, they allow creating various control functions by providing interfaces for valves that may be placed and fixed on their surface areas.



#### Material of manifolds

Manifolds made from aluminum alloy can be generally used up to 250 bar. The gray cast iron manifolds - up to 350 bar, the steel manifolds - up to 420 bar. The maximum allowable operating pressure must be verified for each individual type in the relevant product catalog.

#### Standard and custom-made manifolds

The manufactured manifolds can be divided into two groups. The standard products given in the catalog constitute the first group. For example: subplates, manifolds and modular plates for screw-in cartridge valves, etc. The interesting solutions are the modular assembly blocks a high design flexibility, whether the modular valve assembly RPEK1-03/B of size Dn 03 or the subplates designed for higher sizes (Dn 04, 06, 10).

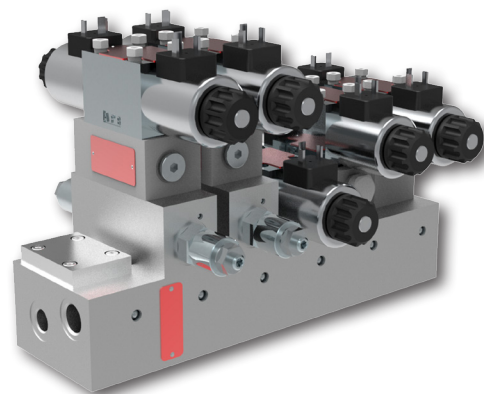
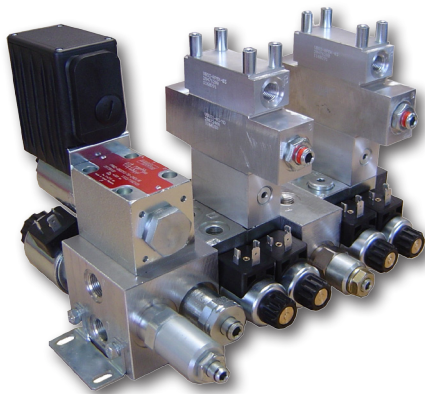

The modular assembly block based on the bankable directional control valves RPEK1-03 of size Dn 03 and the in-line manifold with 6 sections, fitted with the valves of size Dn 06.

#### Multifunctional base plate ZB06

is intended for power pack assemblies. It allows several different basic circuit connections with the pump mounted on the tank cover or placed in the tank. It can be used for the circuit with one accumulator, two pumps or a variable displacement pump. Moreover, the side surface allows the connection of other valves with a housing or valves built into modular plates. The in-line manifold PD together with other valves can be connected to the top surface.

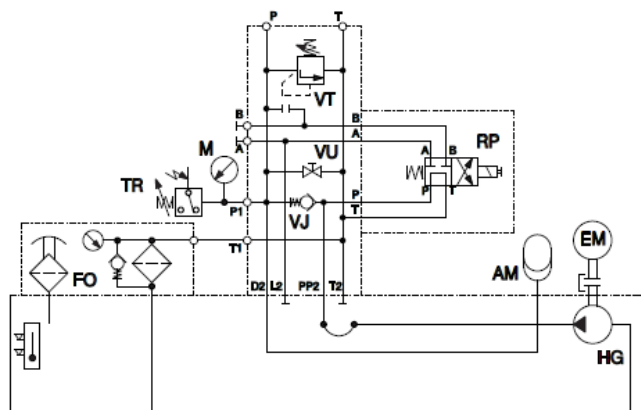
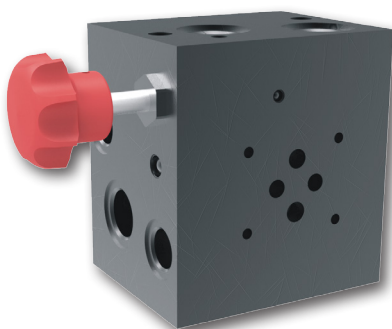

The connection schematic of the switch-mode hydraulic power packs connected using the base plate ZB06.

Manifolds for specific applications constitute the second group. Gray iron castings and aluminum alloy castings are used at higher quantities.

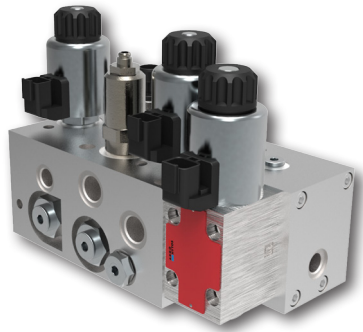

*Special manifold for gearbox control developed in cooperation with a customer.*

### Screw-in cartridge cavity manufacturing tools



For the proper functionality of the screw-in cartridge valves, the cavities allowing their screw-in mounting are of great importance. Their function depends both on observing the dimensions and correct cavity geometry. These requirements can be met technologically only when using special custom-made forming tools made from high-speed steel. A overview of the tools for cavity machining can be found in the catalog SMT 0019.

### 3.4. Hydraulic power packs

These systems are complete hydraulic drives to which the customer may connect their actuators, e.g. hydraulic cylinders or hydraulic motors. The power packs are developed and modified according to the customers' needs to satisfy their requirements in full. The manufactured power packs are divided into three basic design groups – SMA, SPA and SA. Each group has its specific use.

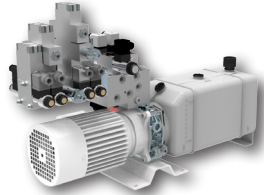
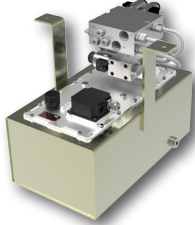
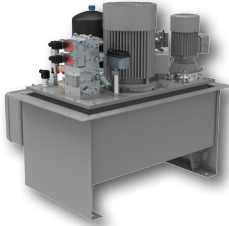
		Nominal power [kW]	Tank volume [dm <sup>3</sup> ]	Max. pressure [bar]	Flow rate [dm <sup>3</sup> min <sup>-1</sup> ]	
SMA	The SMA power packs are characterized by a small installation space, high variability of shapes, types and designs. They are used both for stationary and mobile applications. They are fitted with gear pumps.	0.12 - 3	1.5 - 40	250	0.3 - 17	
SPA	The SPA power packs are used in particular to drive lifting equipment in a small installation space. The submersible motor works in the fluid placed in the tank. The power packs are equipped with gear pumps and possess the added advantage of reduced noise.	0.55 - 3	7 - 30	250	2.2 - 17	
SA	The SA power packs are big hydraulic drives used for stationary applications. They offer enough space for other types of pumps, e.g. axial piston pumps, filtration systems, mounting of various sensors and creating sophisticated circuits by means of vertical and horizontal stacking assembly.	0.55 - 7.5	10 - 250	250	0.5 - 50	

## Useful formulas for calculations

### a) Pump

Required motor output power for specified hydraulic power	Torque on the pump shaft transmitted by clutch
$P_1[kW] = \frac{[Q[dm^3 \min^{-1}] \cdot \Delta p[bar]]}{600 \cdot \eta_c}$	$M_K[Nm] = \frac{V_G[cm^3] \cdot \Delta p[bar]}{20\pi}$
Pump rotation speed necessary to deliver the specified flow	Flow delivered by pump at specified motor rotation speed
$n_1[\min^{-1}] = \frac{Q [l/min] \cdot 1000}{V_G[cm^3] \cdot \eta_Q}$	$Q[dm^3 \min^{-1}] = \frac{V_G[cm^3] \cdot n[\min^{-1}] \cdot \eta_Q}{1000}$
$P_1$ [kW] – motor output power $n_1$ [min <sup>-1</sup> ] – rotation speed of motor or pump $M_{K1}$ [Nm] – torque on the shaft of motor or pump $V_G$ [cm <sup>3</sup> ] – geometric displacement volume of pump	$Q$ [dm <sup>3</sup> min <sup>-1</sup> ] – flow delivered by pump $\Delta p$ [bar] – pressure difference on pump (outlet pressure – inlet pressure) $\eta_c$ – overall pump efficiency (specified by the manufacturer) $\eta_Q$ – flow efficiency of pump (specified by the manufacturer)

### b) Hydraulic motor

Torque on hydraulic motor shaft at specified pressure difference	Rotation speed of hydraulic motor at specified delivered flow
$M_{K2}[Nm] = \frac{V_M[cm^3] \cdot \Delta p[bar] \cdot \eta_{CM}}{20\pi}$	$n_1[\min^{-1}] = \frac{Q[dm^3 \cdot \min^{-1}] \cdot 1000}{V_G[cm^3] \cdot \eta_Q}$
Output power on hydraulic motor shaft	Required flow delivered for specified rotation speed of hydraulic motor
$P_2[kW] = \frac{M_{K2}[Nm] \cdot n_2[\min^{-1}]}{9549}$	$Q[dm^3 \min^{-1}] = \frac{V_M[cm^3] \cdot n_2[\min^{-1}]}{1000 \cdot \eta_{QM}}$
$P_2$ [kW] – output power on hydraulic motor shaft $n_2$ [min <sup>-1</sup> ] – rotation speed of hydraulic motor shaft $M_{K2}$ [Nm] – torque of hydraulic motor shaft $V_M$ [cm <sup>3</sup> ] – geometric volume (maximum usable flow) of hydraulic motor	$Q$ [dm <sup>3</sup> min <sup>-1</sup> ] – flow delivered to hydraulic motor $\Delta p$ [bar] – pressure drop on hydraulic motor (inlet pressure - outlet pressure) $\eta_{CM}$ - overall efficiency of hydraulic motor (specified by the manufacturer) $\eta_{QM}$ – flow efficiency of hydraulic motor (specified by the manufacturer)

### c) Hydraulic cylinders

Force acting on piston rod at specified pressure difference on cylinder	Speed of piston rod at specified inlet flow rate
$F_1[N] = 10 \cdot (p_1[bar] \cdot S_1[cm^2] - p_2[bar] \cdot S_2[cm^2]) \cdot \eta_{pV}$	$v_1[ms^{-1}] = \frac{Q_1[dm^3 \min^{-1}]}{6 \cdot S_1[cm^2]} \cdot \eta_{QV}$
Output power on cylinder piston rod	Required flow delivered for specified speed of piston rod
$P_2[kW] = \frac{F_2[N] \cdot v_1[ms^{-1}]}{1000}$	$Q_1[l/min] = \frac{6 \cdot S_1[cm^2] \cdot v_1[ms^{-1}]}{\eta_{QV}}$
$F_1$ [N] – force on cylinder piston rod $p_1$ [bar] – inlet pressure $p_2$ [bar] – outlet pressure $S_1$ [cm <sup>2</sup> ] – piston effective area $S_2$ [cm <sup>2</sup> ] – piston effective area on rod side	$Q_1$ [dm <sup>3</sup> min <sup>-1</sup> ] – flow entering cylinder $v_1$ [ms <sup>-1</sup> ] – speed of piston movement $\eta_{pV}$ – pressure efficiency of hydraulic cylinder $\eta_{QV}$ – volumetric efficiency of hydraulic cylinder $\eta_{cV}$ – overall efficiency of cylinder = $\eta_{pV} \cdot \eta_{QV}$



#### Basic principles for operation of hydraulic power packs

- › Keep enough working fluid in the tank.
- › Use only recommended types of hydraulic fluid meeting the demands on cleanliness and wear rate.
- › Maintain the recommended temperature of the working fluid.
- › Do not exceed the maximum permitted operation period for the power pack. There is an increased risk of damage especially for DC motors that usually work in different duty types than continuously running duty S1.
- › Observe the marked direction of rotation for rotating machines, such as electric motors or pumps.

**Agreed designation of the direction of rotation:**

If we face the shaft of the rotating machine, the clockwise rotation is right-handed.

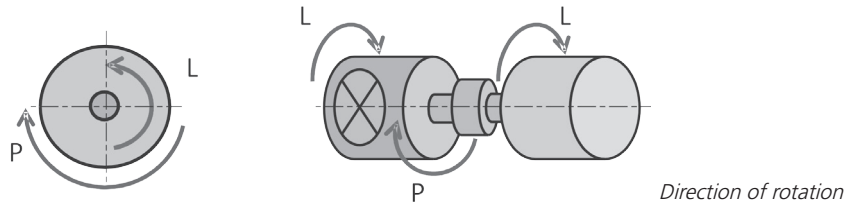
**Accessories**

Apart from the complete products, we offer construction subgroups and accessories such as studs for stacking assembly of modular plates, indicators of filter insert clogging, fluid level gauges, plugs, oil dipsticks, piston hand pumps or pressure switches of various types and designs.



*Hand pump RCA serves as emergency source of fluid under pressure.*



*Digital pressure sensor TSE2-D for system pressure indication and switching at reaching two adjustable pressure values*

**4. Packaging of products**

The valves are normally packed into PE pouches using vacuum sealing. The valves with housing are fitted with a plastic transport plate. Undamaged plates can be returned to the manufacturer.

The outlets of hydraulic blocks and power packs are protected by the plastic plugs.

All products are packaged with respect to the product type, means of transportation and customer's location to avoid corrosion, mechanical damage and contamination of the products.

Various packaging procedures can be applied at the customer's request.

All used packaging materials are recyclable and eco-friendly.

**5. Spare parts and accessories**

Supplied spare parts can be chosen from catalog No. 8010.

Screw-in cartridge directional control valves and poppet valves are delivered without coils. The coils must be ordered separately acc. to the catalog No. 8007.

Valves with housing and proportional valves are delivered with complete solenoids.

Connecting material, such as connecting bolts or studs must be ordered separately.

Studs and nuts used for vertical stacking assembly are listed in the catalog No. 0020.

## 6. Installation



### Mounting position

The valve mounting position is usually arbitrary if is not stated otherwise in the catalog. If shocks and vibrations occur during operation, we recommend that the direction of disturbance be not identical to the direction of spool / poppet movement to avoid any effect on their positions.

For hydraulic power packs, the position is determined by the tank orientation.

### Mounting surfaces and cavities

The mounting surfaces of valves with housing described in ISO 4401 and cavity for the screw-in cartridge valves are given in the catalog No. 0019. The forming tools for manufacturing the cavities are also included in the catalog. For proper functionality of the screw-in cartridge valve, it is necessary to maintain dimensions, roundness and concentricity of internal cavity diameters and connecting threads. Furthermore, the common axis must maintain its perpendicularity to the front bearing surface.

The tolerable surface roughness inside the cavity is  $R_a=1.6$ . When machining the bearing surfaces for sealing rings, it is necessary to keep the specified surface roughness  $R_a=0.8 / R_{MAX}=6.3$  and flatness  $0.01 / 100 \text{ mm}$ .

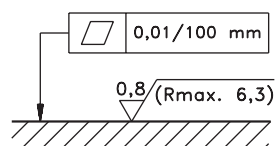

Required surface quality of the counterpart

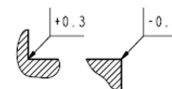
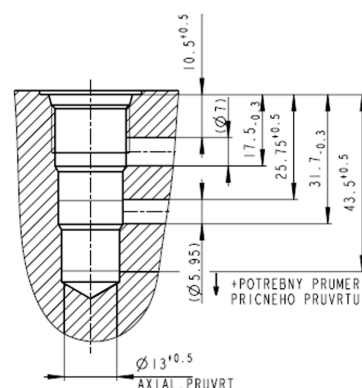
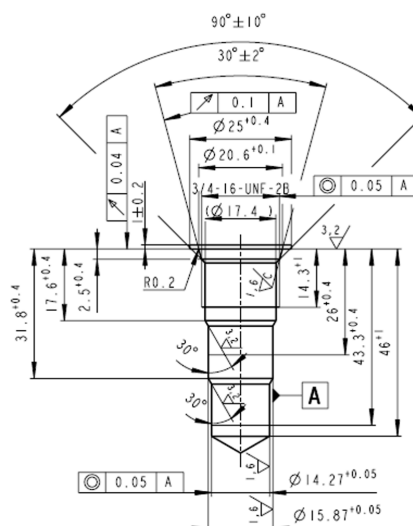

## 7. Classification of ARGO-HYTOS products into groups according to level of danger

1. Actuating solenoids of the valves and control electronic units of the proportional valves produce an electromagnetic field. They are the specified products for conformity assessment in accordance with:
  - › The Government Regulation No. 117/2016 Coll. The government regulation on conformity assessment of products in terms of electro-magnetic compatibility, when placed on the market
  - › Directive 2014/30/EU of the European Parliament and of the Council of 26 February 2014 on the harmonization of the laws of the Member States relating to electromagnetic compatibilityThe technical documentation was prepared, the product conformity was assessed, the declaration of conformity was issued and the products were marked with the CE marking.
2. Actuating solenoids with supply voltage higher than 50 or 75 V DC are the specified products for conformity assessment in accordance with:
  - › The Government Regulation No. 118/2016 Coll. The government regulation on conformity assessment of electrical equipment designed for use within certain voltage limits delivered to the market
  - › Directive 2014/35/EU of the European Parliament and of the Council of 26 February 2014 on the harmonization of the laws of the Member States relating to the marking available on the market of electrical equipment design for use within certain voltage limits.The technical documentation was prepared, the product conformity was assessed, the declaration of conformity was issued and the products were marked with the CE marking.
3. The power packs are partly completed machinery in accordance with:
  - › The government regulation on technical requirements for machinery (§1 letter g, definition §2 letter g)
  - › Directive 2006/42/EC of the European Parliament and of the Council of 17 May 2006 on machinery, and amending Directive 95/16/EC (recast) (Article 1 "Scope" – g "partly completed machinery", Article 2 "Definitions" – g)The technical documentation was prepared, the product conformity was assessed, the declaration of conformity was issued and the products were marked with the CE marking. The partly completed machinery is not marked with the CE marking. The partly completed machinery must not be put into service until the final machinery into which it is to be incorporated has been declared in conformity.
4. The safety components are the specified products in accordance with:
  - › The Czech Government Regulation No. 176/2008 Coll. on technical requirements for machinery (§1 letter c, definition §2 letter c)
  - › Directive 2006/42/EC of the European Parliament and of the Council of 17. May 2006 on machinery, and amending Directive 95/16/EC (recast) (Article 1 "Scope" – c "safety components", Article 2 "Definitions" – c)The technical documentation and instructions were prepared, the product conformity was assessed, the declaration of conformity was issued and the products were marked with the CE marking.
5. The hydraulic power packs or blocks can contain hydraulic accumulators and pressure relief valves which are specified in accordance with:
  - › The Government Regulation No. 219/2016 Coll. The government regulation on conformity assessment of pressure equipment when made available on the market
  - › Directive 2014/68/EU of the European Parliament and of the Council of 15 May 2014 on the harmonization of the laws of the Member States relating to the marking available on the market of pressure equipmentThe manufacturer's data report is attached to the accumulator. Among other things, this report contains the product documentation, functional safety calculations, pressure test results and the declaration of conformity. The pressure equipment is subject to regular inspection tests.
6. The hydraulic components designed for use in potentially explosive atmospheres are the specified products in accordance with:
  - › The Government Regulation No. 116/2016 Coll. The government regulation on conformity assessment of equipment and safety systems designed for use in potentially explosive atmospheres when made available on the market
  - › Directive 2014/34/EU of the European Parliament and of the Council of 26 February 2014 on the harmonization of the laws of the Member States relating to equipment and protective systems intended for use in potentially explosive atmospheresThe technical documentation and instructions were prepared, the product conformity was assessed, the declaration of conformity was issued and the products were marked with the CE marking.
7. The hydraulic power packs and block are generally the components designed for the assembly of hydraulic circuits and they are not the specified products for conformity assessment. Subject to the general safety principles for mounting, handling and operation of hydraulic equipment.
8. Please note that the machinery manufactured by customers is subject to other legal regulations according to their field of application. For example:
  - › The Czech Government Decree No. 9/2002 Coll. on the product technical requirements related to the noise emission
  - › Directive 2000/14/EC of the European Parliament and of the Council of 8. May 2000 on the approximation of the laws of the Member States relating to the noise emission in the environment by equipment for use outdoors

## 8. General safety principles for installation, handling and operation of hydraulic equipment



1. The products are intended for the assembly of hydraulic circuits for stationary and mobile equipment.
2. Assembly, installation, commissioning and adjustment of pieces of hydraulic equipment or their parts may only be performed by trained staff with an appropriate qualification.
3. When mounting the hydraulic equipment, use only clean components. Do not allow impurities to ingress from the surrounding environment. Avoid formation of secondary pollution using only undamaged parts which correspond to the applicable drawings.
4. When handling a hydraulic circuit or its parts, the circuit must be disconnected from the power supply and without pressure (including the accumulator). Special care should be taken to avoid any damage of circuit parts or personal injury due to a fall of equipment. Very heavy products (such as power packs or manifolds) are provided with handling accessories - lifting eye bolts. Follow the instructions (if any) for the product installation containing guidelines for handling and the method of product attachment.
5. Individual circuit parts must be tightened using the recommended torques. The loose parts are the spots of working fluid leakage. The excessive tightening can cause damage to parts or their deformation. It will be reflected by malfunctioning or loss of functionality.
6. Mineral oils specified in the product catalog may be used as the working fluid. To use other fluids, first consult with ARGO-HYTOS. Using aqueous solutions as the working fluid is impossible.
7. Mineral oil is a fluid harmful to the environment. Prevent leakage of the working fluid. Check the circuit tightness after installation. If there is leakage of working fluid, it will be necessary to dispose of it ecologically including contaminated objects, bulk materials and earths.
8. Dispose the old working fluid in an eco-friendly manner.
9. In the case of contamination of people by the working fluid, the contaminated clothing must be removed immediately and skin must be washed with common skin tolerant detergents. In case of any allergic skin reaction caused by the working fluid, eye irritation or fluid ingestion, seek medical assistance immediately!
10. Keep the surroundings of equipment clean. There is a danger of slipping, falling or otherwise injury of people.
11. Viscosity of the working fluid must not exceed the range given in the product catalog. Especially when starting the equipment at low temperatures, viscosity increases to a critical value. It can lead to malfunction of the circuit. In this case, it is necessary to heat the fluid to an acceptable temperature before switching on the equipment.
12. The electrical parts of the circuit (electric motors, switches, sensors, actuating solenoids, control electronics, etc.) must comply with all applicable legal regulations and technical standards. They must be connected to the power supply in the manner specified in the product catalog. The electrical parameters of the source must be respected. The electrical connections may only be performed by a persons with an appropriate qualification. Before working on the electrical installation, the electrical equipment must by disconnected from the power supply and without pressure (including the accumulator).
13. The electrical installations must be executed such that no electrical parts may be damaged mechanically due to the machinery's functions. The insulating material of the conductors must be resistant to chemical actions of the working fluid. If there is any damage to the conductors, plug connectors or other parts of electrical equipment, the equipment must be immediately disconnected from the power supply and the damaged part replaced.
14. Ambient and working fluid temperatures must not exceed the values specified in the product catalog. High temperature leads to a decrease of the power on the actuating solenoids due to resistance increase of the coil winding. High temperature also harms the applied seals irreversibly. Don't touch the circuit parts at higher temperature of the working fluid. The surface of the components is gradually heated up to the fluid temperature and there is a risk of burns. Irreversible transformation of energy loss to heat leads to heating the surface of the solenoids. When placing the hydraulic circuit and its components in an enclosed space without air circulation, it is necessary to check the maximum ambient temperature and the working fluid temperature and make sure there is no overheating. If the circuit cannot be cooled enough through heat transfer by natural convection and radiation, a cooling unit of adequate cooling capacity must be put into the circuit.
15. Products must be protected from the effects of excessive heat and electrical discharges, mechanical damage, excessive vibrations and shocks, from the effects of aggressive chemical substances and highly corrosive environment.
16. While the circuit is loaded with pressure, it is forbidden to disconnect or dismount its parts. There is a risk of ejection of a loose part owing to fluid pressure and massive fluid leakage.
17. Although the circuit parts are designed with a sufficient resistance to internal overpressure of the working fluid, the maximum pressure value of individual parts of the circuit must not exceed the limits specified in the product catalog. The pressure peaks occur due to the dynamic changes of pressure and flow rate during circuit operation. These peaks can exceed the maximum static pressure many times. Exceeding the maximum allowable pressure can cause the loss of functionality and the circuit destruction.
18. Mineral oils are flammable fluids of Class III. The principles of fire prevention must be followed for fluid storage, handling and filling to the circuit. When installing a heating element into the tank together with the working fluid, overheating of the fluid and ignition of vapors must be avoided. Input power of the heating element should not exceed 1 W/cm<sup>2</sup> to prevent carbonization of oil on the housing surface.
19. Keep the recommended cleanliness of the working fluid as specified in the product catalog using high quality filtration. The fluid cleanliness significantly affects the wear of mechanical components and their functions, in particular pilot operated and poppet type valves. The hydraulic circuit must be protected against the ingress of hard particles such as quartz or abrasive materials causing hard wear and the loss of functionality in a short time.
20. Hydraulic equipment may be operated only by authorized staff after having been sufficiently acquainted with the features and operation of the equipment, is aware of possible risks, knowledgeable about preventive measures and the required operations when critical situations occur. If there is any damage to the circuit parts or malfunction, the circuit must be immediately disconnected from the power supply and pressure source. Then contact authorized service. Any improper handling of hydraulic equipment is prohibited.



## 9. Reliability of products according to EN ISO 13849

The valves of ARGO-HYTOS are designed and manufactured in accordance with the standard **EN ISO 13849-1:2015, Annex C, paragraph C. 3**, with respect to "fundamental" and "proven" safety principles.

The following  $MTTF_d$  values follow from this approach for our products:

- valves → 150 years
- valves with external pilot → 75 years, e.g. directional control valves size Dn 16 and Dn 25 with the pilot valve

**Specific  $MTTF_d$  values for particular applications:**

Apart from this, the component can be considered different from the standard EN ISO 13849-1, Annex C. This approach is based on the calculation of the specific  $MTTF_d$  value for particular application.

**As a basis for the calculation (see formula), it is necessary to know the following values:**

- ›  $B_{10d}$  (mean number of cycles to a dangerous failure of 10 % of components)
- ›  $n_{op}$  (mean number of cycles per year)
- ›  $d_{op}$  (mean time of operation expressed in days per year)
- ›  $h_{op}$  (mean time of operation expressed in hours per day)
- ›  $t_{cycle}$  (mean time between two successive cycles of component, e.g. valve switching on, expressed in seconds per one cycle)

$$MTTF_d = \frac{B_{10d}}{0,1 \times n_{op}} \qquad n_{op} = \frac{d_{op} \times h_{op} \times 3600}{t_{cyklus}}$$

MTTF is an abbreviation for „mean time to failure“. For the assessment according to EN ISO 13849-1, only failures leading to a dangerous situation are taken into account.

This value is a theoretical parameter expressing the probability of component failure (not of the whole assembly) which leads to a dangerous situation in the course of the component service life. The assembly service life is always shorter due to the interconnection of several components.

**MTTF value can be derived from the frequency of failures. The frequencies of failures are as follows:**

- ›  $B_{10}$  value for electromechanical and pneumatic components. In this case, service life depends on the switching frequency.  $B_{10}$  value indicates the number of switching cycles before the failure of 10 % of parts.
- ›  $B_{10d}$  value indicates the number of switchings before a dangerous failure of 10 % of parts occurs. If the  $B_{10d}$  value is not available, the calculation  $B_{10d} = 2 \times B_{10}$  can be accepted as a simplification.
- › For the electronic components, the frequency of failures is expressed by the value of lambda ( $\lambda$ ). The frequency of failures is often expressed as FIT (Failures In Time). One FIT means one failure in  $10^9$  hours.

**The standard EN ISO 13849-1 summarizes  $MTTF_d$  values into the following areas:**

Designation	Range
Low	3 to 10 years
Medium	10 to 30 years
High	30 to 100 years

Mean time to failure (expressed in years) leading to a dangerous situation ( $MTTF_d$ ) can be calculated from data on the parts.

**Graph:**

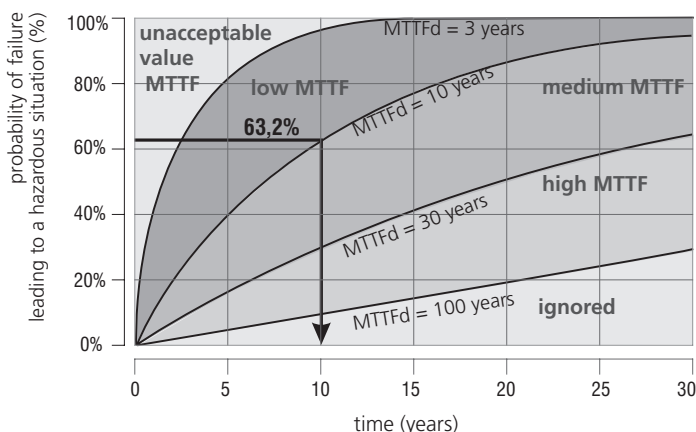

The example indicated in the graph: time - 10 /  $MTTF_d$  value - 10 years → probability of failure leading to a dangerous situation - 63.2 %

## 10. Applied materials

The products are made of common engineering materials, such as low-carbon steel, carbon steel and alloy steel, gray cast iron, brass and AlMgSi alloys. The coil windings are made of enameled copper wire and plastic parts are made of polyamide. The seals are also made of common materials, such as NBR, HNBR, VITONU, PUR or silicone. Surface treatment performed by zinc-coating doesn't include hexavalent chromium Cr<sup>6+</sup>. Materials originating from illegal sources are not processed.

The applied manufacturing, mounting and testing procedures do not have any detrimental effect on the health of workers and the environment. Compliance with the applicable legal regulations, standards and regulations relating to safety at work, fire protection, hygiene, environmental protection and defending workers' rights is checked by the national supervisory bodies.

### **The applied materials and processes meet the requirements of the following legal regulations:**

- › Regulation (EC) No. 1907/2006 of the European Parliament and of the Council concerning the registration, evaluation, authorization and restriction of chemicals (REACH)
- › Directive 2011/65/EU of the European Parliament and of the Council on the restriction of the use of certain hazardous substances in electrical and electronic equipment (RoHS)
- › Law H.R. USA No. 4173 (Dodd-Frank) - Sec. 1502 about conflict minerals originating from illegal sources

### **Original documents:**

- › Regulation (EC) No. 1907/2006 of the European Parliament and of the Council of 18 December 2006 concerning the Registration, Evaluation, Authorization and Restriction of Chemicals (REACH), establishing a European Chemicals Agency, amending Directive 1999/45/EC and repealing Council Regulation (EEC) No. 793/93 and Commission Regulation (EC) No. 1488/94 as well as Council Directive 76/769/EEC and Commission Directives 91/155/EEC, 93/67/EEC, 93/105/EC and 2000/21/EC.
- › Directive 2011/65/EU of the European Parliament and of the Council of 8 June 2011 on the restriction of the use of certain hazardous substances in electrical and electronic equipment (RoHS)
- › Dodd-Frank Wall Street Reform and Consumer Protection (U.S. Act, HR 4173) - § 1502 "Conflict Minerals", article (4A)

## 11. Validity of catalogs

All technical data given in the product catalogs serve only descriptive purposes and cannot be interpreted as legally or contractually guaranteed product properties.

We recommend using our website [www.argo-hytos.com](http://www.argo-hytos.com) where continuously updated versions of the catalogs are available.